



**Exercise
100B**

Fundamental electrical measurements

Instruction

I. Laboratory apparatus list

- Stabilized power supply
- Multimeters (2x)
- Electrical wires
- Set of resistors

II. The purpose of the exercise

- Getting Acquainted with the basic electrical tools (including the measurements methods, measurement errors and instrument inaccuracies)
- Determination of electric current passing through the resistor as the function of voltage
- Analysis of the obtained results and report writing training

III. Measurements instruction



a) Connect the resistor with the multimeter as below

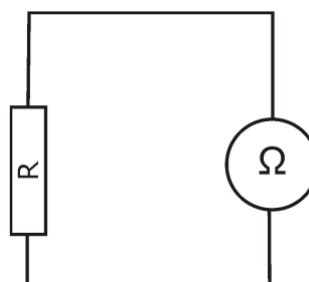

- b) Measure the resistance value of each resistors.
- c) Connect the setup according to the scheme

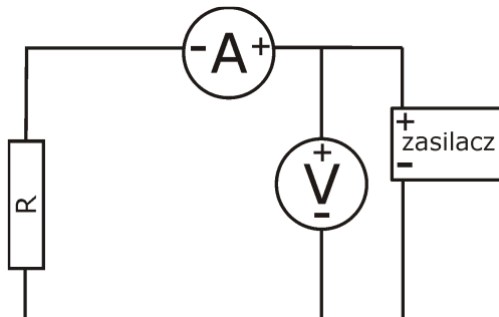

- d) Changing the voltage applied to resistor read the value of current flowing through the resistor

IV. Analysis of the results

- Estimate the uncertainty of resistance $u(R)$
- Plot a graph $I=f(U)$, where I – current [A], U – voltage [V]
- Using a linear regression model estimate the resistance value and its uncertainty
- Compare this value with the value of resistance obtained in point III (a)

V. The table example

Lp.	U [V]	$u(U)$ [V]	I $\times 10^{-3}$ [A]	$u(I)$ $\times 10^{-3}$ [A]	R [Ω]	$u_c(R)$ [Ω]
1						
2						
...						
n						